



Pizza Favourite



*AB Borås Ugntjänst
Sweden*

Pizza Favourite

This is the oven that make your bake to a joy.

Pizza Favourite is produced so that the fastidious baker shall be satisfied.

High Standard

Pizza Favourite is equipped with top cover, sliding leaf, thick stone hearts, stable oven door with thick heat reflective glass. The oven is electronically controlled with a digital viewing. Favourite have turbofunktion, and is built with additional front heating.

Stainless steel facing, makes the oven easy to keep clean.

Performance

Our ovens are very good insulated. Producing very low heatradiation, wich provides a pleasent working environment for the user. A well insulated oven uses less energy wich results in better overall operational economy.

Lighting

Pizza Favourite have very good lighting from both side. (PZ 4, lit from one side)



Electronic controll

Pizza Favourite is electronically controled wich makes it very economical. Each deck have three switches for heat regulation, front, top and back.

Turbo

The turbofunktion automatically goes on when you start up the oven. You can turn on or off the turbofunktion whenever you like. For example it's perfect when you have topp charge.



Economy

The oven is equipped with 120 mm thick insulation. Thanks to the thick insulation and electronic control, we can provide an economy oven which consumes less energy.

Options

Lower shelf between the legs, for pizzacartons e.g.

Timer for 24 hours time setting a week.

Module built

Pizza Favourite is a module built oven. We produce up to three decks in one oven. If you want to start small, we can deliver only one oven deck, and you can increase the number of oven decks at your own rate according to your own needs. A module built oven is easy to take in divided, if it is crowded.

Solid Legs

We deliver the oven with stainless steel legs, and castors. The front castors are lockable.

Five sizes

The oven can be delivered in five different sizes, which can be seen on the last page of this brochure. Everything after your wishes.

Top Cover

Favourite are delivered with top cover, for proximity to local ventilation.



Pizza Favourite
The oven for the Pizzabaker

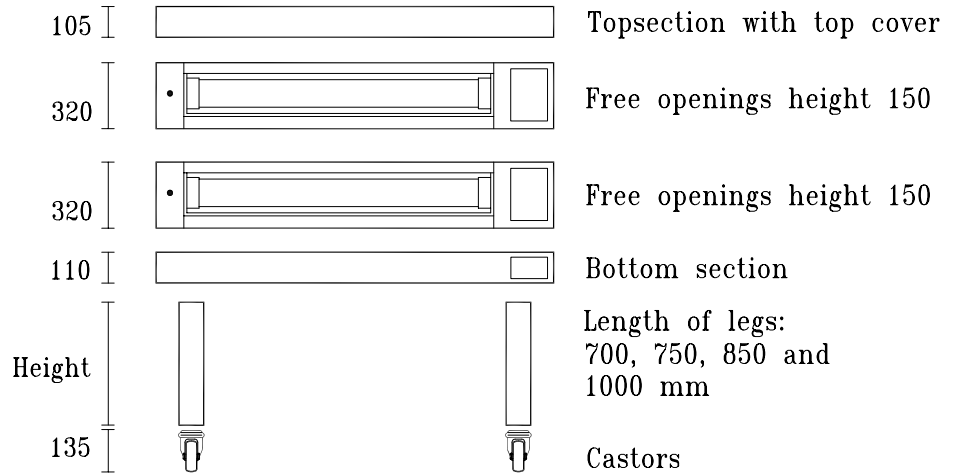
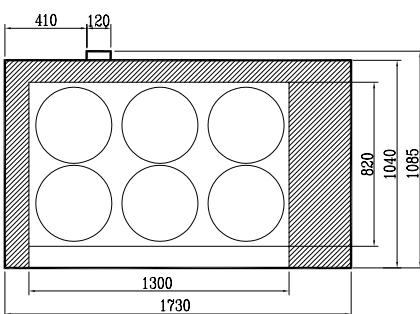
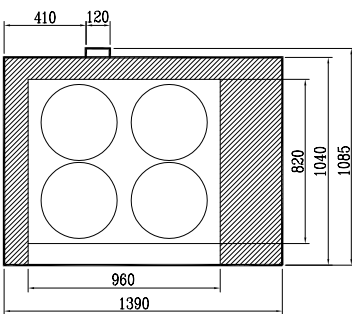
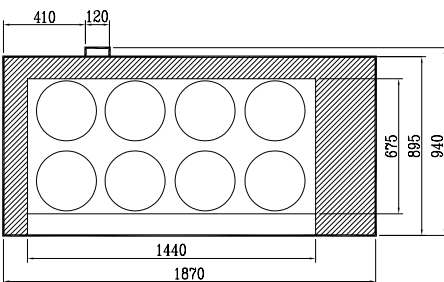
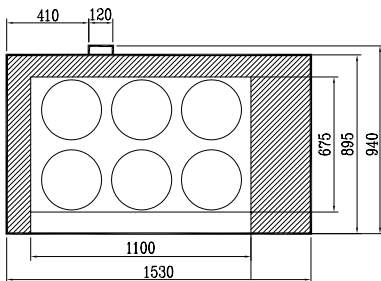
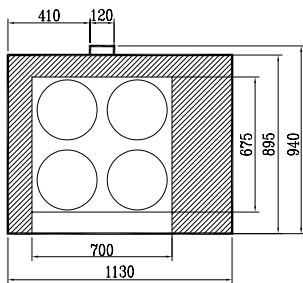

Power/Oven chamber, kW

	220V	380V	400V	415V
4 Pizzas	5,5	5,0	5,5	6,0
4 Piz./large	7,8	7,1	7,8	8,4
6 Pizzas	7,8	7,1	7,8	8,4
6 Piz./large	10,5	9,5	10,5	11,3
8 Pizzas	9,5	8,6	9,5	10,2

Features in the standard model:

- Stainless steelfacing
- Each deck is regulated separately
- Breakers for heat regulation, front-, over- and underheat.
- Turbofunction
- Working temperature showed in display
- Sliding leaf
- Legs in stainless with castors, of which two are lockalbe
- Stable oven door with thick heatreflective glass
- Top cover
- Excellent light from both sides
- Modul built
- Five sizes



Optional equipment:

- Lower shelves between the legs, for storage
- Timer with 24 hours time setting a week



AB Borås Ugntjänst
 Kypered 3
 S-504 90 Borås, Sweden
 Tel. +46 (0)33-243108, 243120
 Fax +46 (0)33-243108
 Email abbu@telia.com
 www.abbusweden.com